



Mirage - Top Flush Suite

SUITE-MIRAGE TF-WHI

CISTERN-MIRAGE/IQWA TF-WHI

PANS-MIRAGE-**

SEAT-MIRAGE **(WOOD)

MECH-UNIVERSAL DUAL FLUSH (WIRQ)

FIX-PAN FIXATION KIT (L BRACKET) SEREX

CLOSE COUPLE, OPEN RIM, TOP FLUSH

WEIGHT OF PAN:	28,3 kg
WEIGHT OF CISTERN:	12.3 kg
CISTERN WATER CAPACITY:	10 Lt
PAN FLUSH VOLUME:	3/6 Lt
PAN WIDTH:	365 mm
PAN HEIGHT:	400 mm
CISTERN WIDTH:	395 mm
CISTERN HEIGHT:	382 mm
COMBINED HEIGHT:	825 mm
INSTALLED MAX LENGTH:	665 mm

The Mirage is a top flush suite.

MIRAGE SUITE INSTALLATION GUIDE:

1. Fit inlet valve and flushing mechanism, as per manufacturer's instructions.
2. Attach cistern to pan using fixation bolts.
3. Fit seat, use the manufacturer's instructions.
4. Place the pan with cistern on flat (even) surface for best results.
5. Make markings on floor surface, for drilling of fixation holes (pan).
6. Remove pan and cistern, drill holes into concrete floor.
7. Slide outlet of pan onto bung of outlet pipe fitted by a qualified plumber.
8. Attach pan to floor using screw fixations.
9. Connect to the water supply.

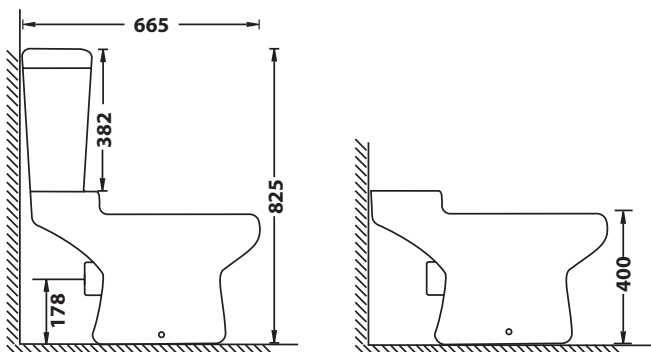

AVAILABLE COLOURS:

WH



10
YEAR
WARRANTY

